



SM5

Compact Vandal Resistant, Surface-Mount Dome

The SM5 Series from Moog offers a vandal resistant, surface-mounted solution that provides superior camera protection in a compact size. Engineered with rugged, high-impact polycarbonate, the SM5 is designed to withstand volatile attacks and varying harsh weather conditions.

The versatile enclosure is compatible with several of today's leading camera systems (fixed and PTZ), and includes a 5.9" (149.9mm) optically transparent, UV-stabilized, thermoplastic polycarbonate dome ensuring optimal performance. A thermostatically controlled heater / blower is standard for all outdoor models.

Available Features

- Rugged polycarbonate camera enclosure
- Low profile design ideal for smaller camera systems
- Simple camera installation
- Designed for use with IP and analog camera systems (fixed and PTZ)
- Includes impressive 5-year warranty
- PoE models are also available
- Surface mount or pendant mount, using a 1" (25.4mm) standard pipe thread
- Meets IP66 standards
- Outdoor models available with thermostatically controlled heater / blower option
- Great for: schools, parking garages, warehouses, and other applications



SM5/5

Tinted and clear domes available. Specify "C" for Clear or "T" for Tinted.

Outdoor / Indoor PTZ Models:

SM5C2N / ISM5CN

The SM5C2N is the outdoor model for a PTZ camera. Compact vandal resistant polycarbonate surface mount dome. Clear dome, heater / blower, and a 24Vac / 12Vdc power supply ideal for a network IP PTZ camera. Includes a bracket for fixed cameras. 50 watt wall transformer
ISM5CN Indoor version with no electronics

SM5C24N

The SM5C24N is the outdoor model for a PTZ camera. Compact vandal resistant polycarbonate surface mount dome. Clear dome, heater / blower, and 24Vac input, ideal for a network IP PTZ camera. Includes a bracket for fixed cameras

SM5C8N

Compact, outdoor surface-mount dome housing for PoE enabled fixed and PTZ cameras. DPA system, 30W, 100-240Vac input, midspan included (see supported cameras) *SM5C8NE Does not include midspan*

Compatible Cameras:

Mounting brackets are included and can accommodate most of today's popular cameras. To view the latest listing of compatible cameras please visit:

www.moogs3.com/technical-support/tools-software/camera-compatibility-tool/

PTZ:

(ACTI) ACM-8201/8211, ACM-8511, CAM-6510

(Arecont) AVS100

(Axis) 214, 215, 232D, 233D, P55 Series

(Canon) VB-C300, VB-C50i, VB-C60, VC-C50i

(Panasonic) WV-NS202A, WV-SC385, WV-SC384, WV-CS954 / WV-NS954, BB-HCM580 / 581, WV-CS584, WV-SC386, WV-CS574

(SONY) SNC-RZ50

(TOSHIBA) IK-WB21A

Fixed Compatible Cameras Also Available:

Accepts maximum camera length (MCL) 5"

Accessories:



WM10G

Aluminum gooseneck wall mount (shown with SM5 attached), with a 1" NPT thread

PMSM5

Sunshield (shown with optional WM20G wall mount attachment), with a 1½"NPT thread

Mechanical Specifications	
Size (h*w*d):	8" x 8.5" x 8.4" (203.2 x 215.9 x 213.36mm)
Weight:	2.3 Lbs. (1.04 Kg)
Consumption	Body: Polycarbonate
	Trim Ring: Polycarbonate
	Dome: Polycarbonate

Electrical Specifications	
Power Requirements	
Heater and Blower:	40W max
Heater and Blower:	24Vac

Environmental Specifications	
Operating Temperature:	-40°F to 122°F (-40°C to 50°C)
Heater Activates at:	60°F (15°C)
Operating Humidity:	Up to 100%
Meets IK10 Specifications	

Shipping Specifications		
Model	Shipping Weight	Box Dimensions
SM5:	5 Lbs. (2.27 Kg.)	9" x 9" x 11.4" (228.6 x 228.6 x 289mm)

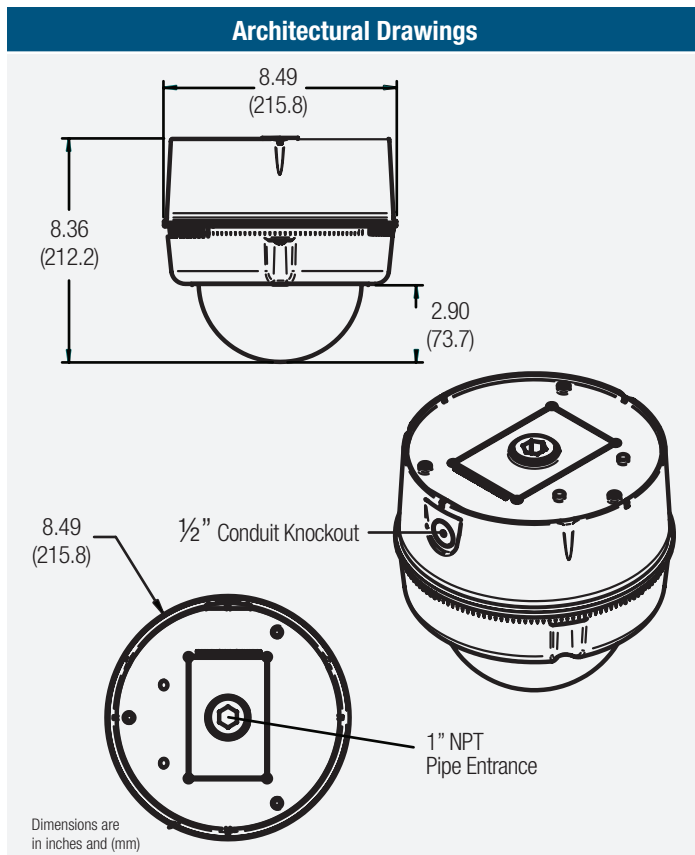

MOOG

Sensor and Surveillance Systems

3650 Woodhead Drive Northbrook, IL, USA 60062

+1.847.498.0700 Fax: +1.847.498.1258 www.moogS3.com